

HEV Market 2008

(株)ハイエッジ
東谷仁志

2009年 LIB Hybridの登場

2009年

Daimler 発売

2010年

Toyota、GM発売

Nissan発売

Saft/Hitachi/AESC

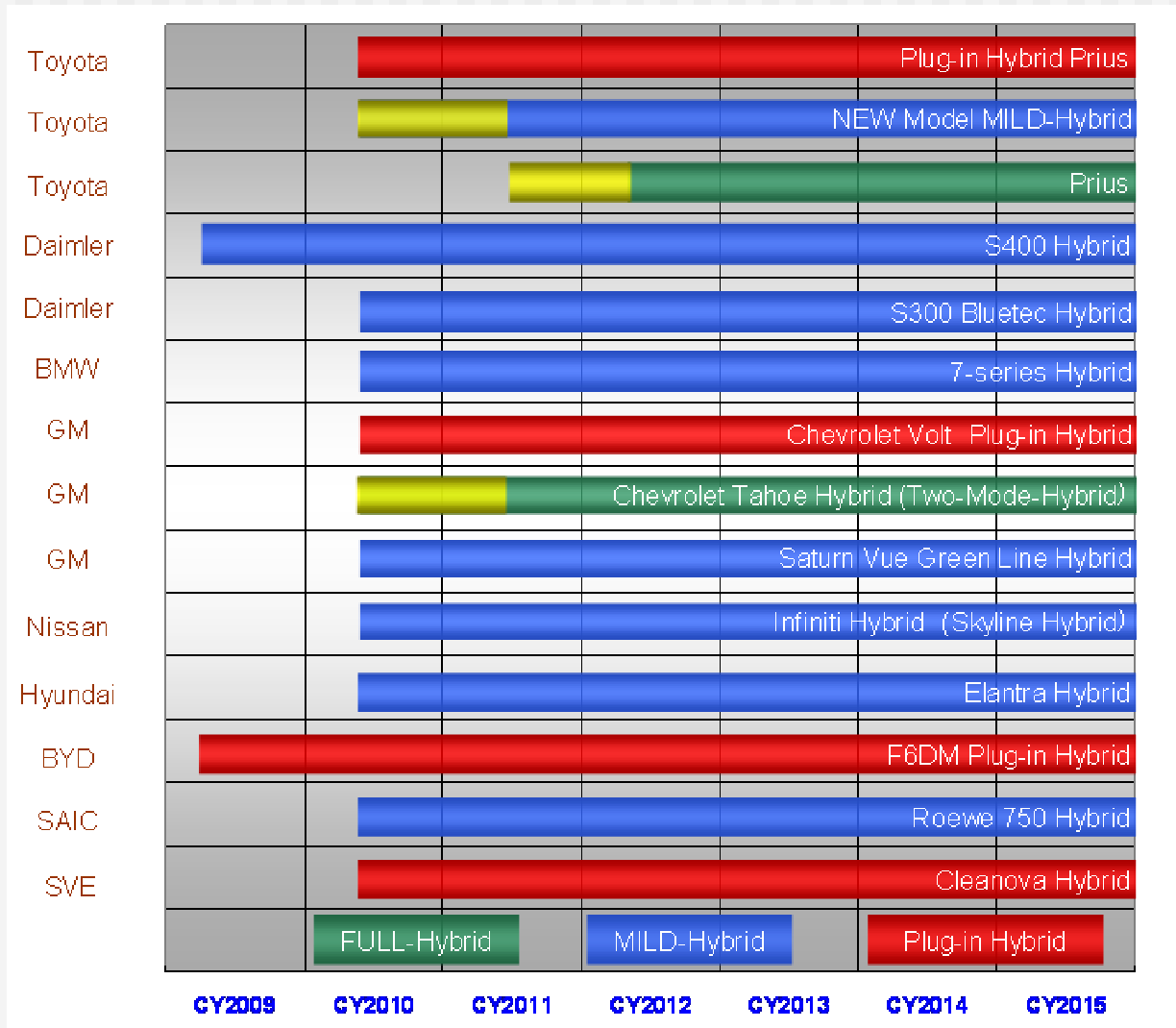

Daimler S400 Hybrid



ZF FriedrichshafenのMILD-Hybrid Cluth+1Motor
Johnson Controls-SaftのLIB

欧州で2010年20万台の生産計画(Daimler、BMW、VW他)

Model	Market date	Hybrid type	Fuel	Motor	Battery	Fuel Economy
ML 450 Hybrid	2009	Two-mode	Gasoline	45 kW	NiMH	7.7 l/100km
				75 kw		30.5 mpg
S 400 Hybrid	2009	Mild	Gasoline	15 kW	LIB 120V	7.9 l/100km 30 mpg
E 300 BLUETEC Hybrid	2010	Mild	Diesel	15 kW	LIB 120V	5.1 l/100km
						46 mpg
S 300 BLUETEC Hybrid	2010	Mild	Diesel	15 kW	LIB 120V	5.4 l/100km
						44 mpg
C 300 BLUETEC Hybrid	2011	Mild	Diesel	15 kW	LIB 120V	4.6 l/100km
						51 mpg
S 400 BLUETEC Hybrid	after 2010	Mild	Diesel	15 kW	LIB 120V	5.8 l/100km
						40.5 mpg
S 400 BLUETEC Hybrid	after 2010	Mild	Diesel	45 kW	LIB	



Hitachi-Vehicle-Energy LIB



GMのMILD-Hybrid

Hitachi-Vehicle-EnergyのLIB

2010年10万台の生産計画



Specification	Single cell	Module
Cell arrangement	-	48 Cells in series
Nominal Voltage (V)	3.6	173
Rated capacity (Ah)	5.8	5.8
Dimensions (mm)	Φ40×108	611×318×103
Mass (kg)	0.3	23
Specific Power (w/kg) @50% SOC	3000	1850
Specific Energy (wh/kg)	69.6	43.6



Nissan Infiniti G Hybrid

Nissan LIB Hybrid 2010年

Automotive Energy SupplyのLIB

2010年2万台～

2009年～ Altima Hybrid へのLIB搭載 ?

ZF FriedrichshafenのMILD-Hybrid ?



LIB Hybrid 2015年 178万台

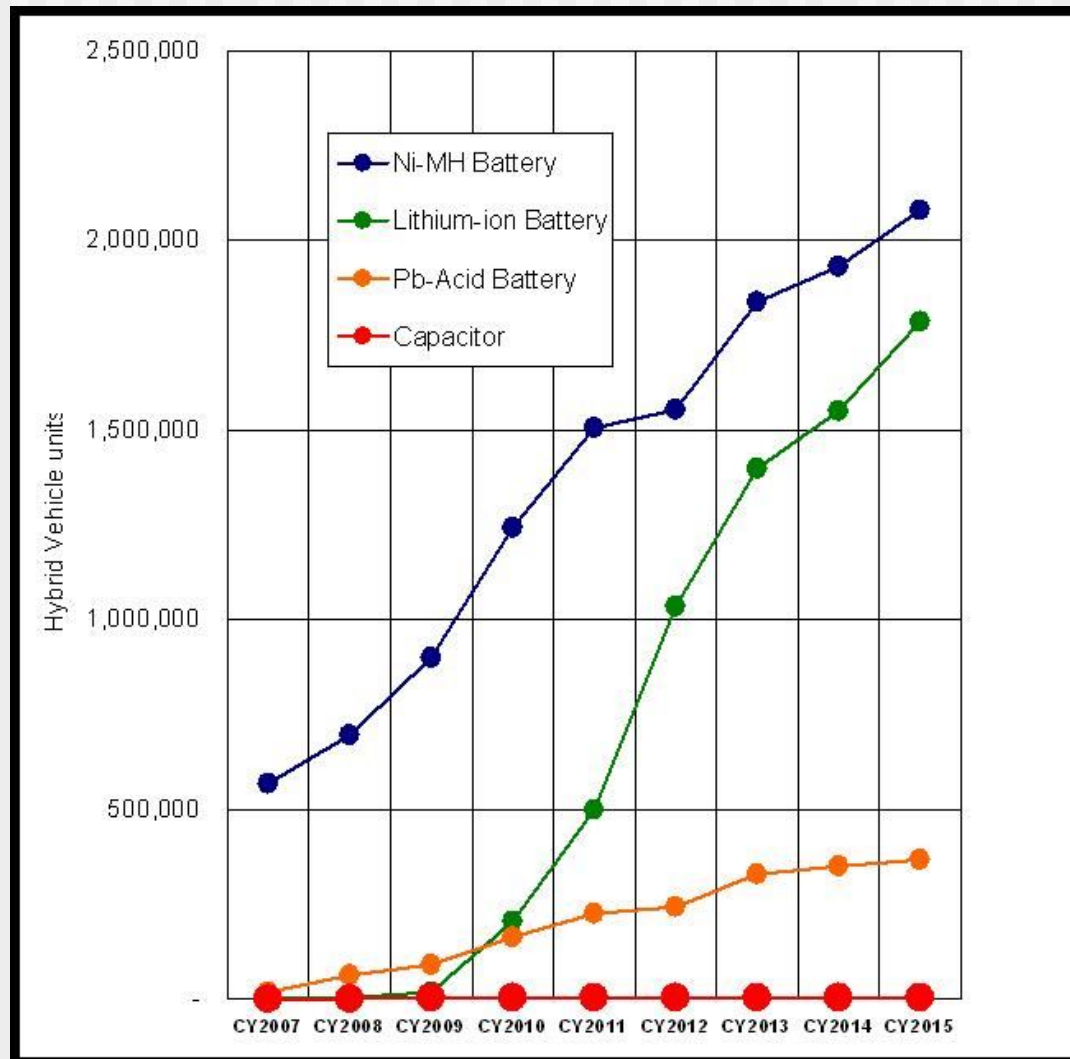

LIB Supplier

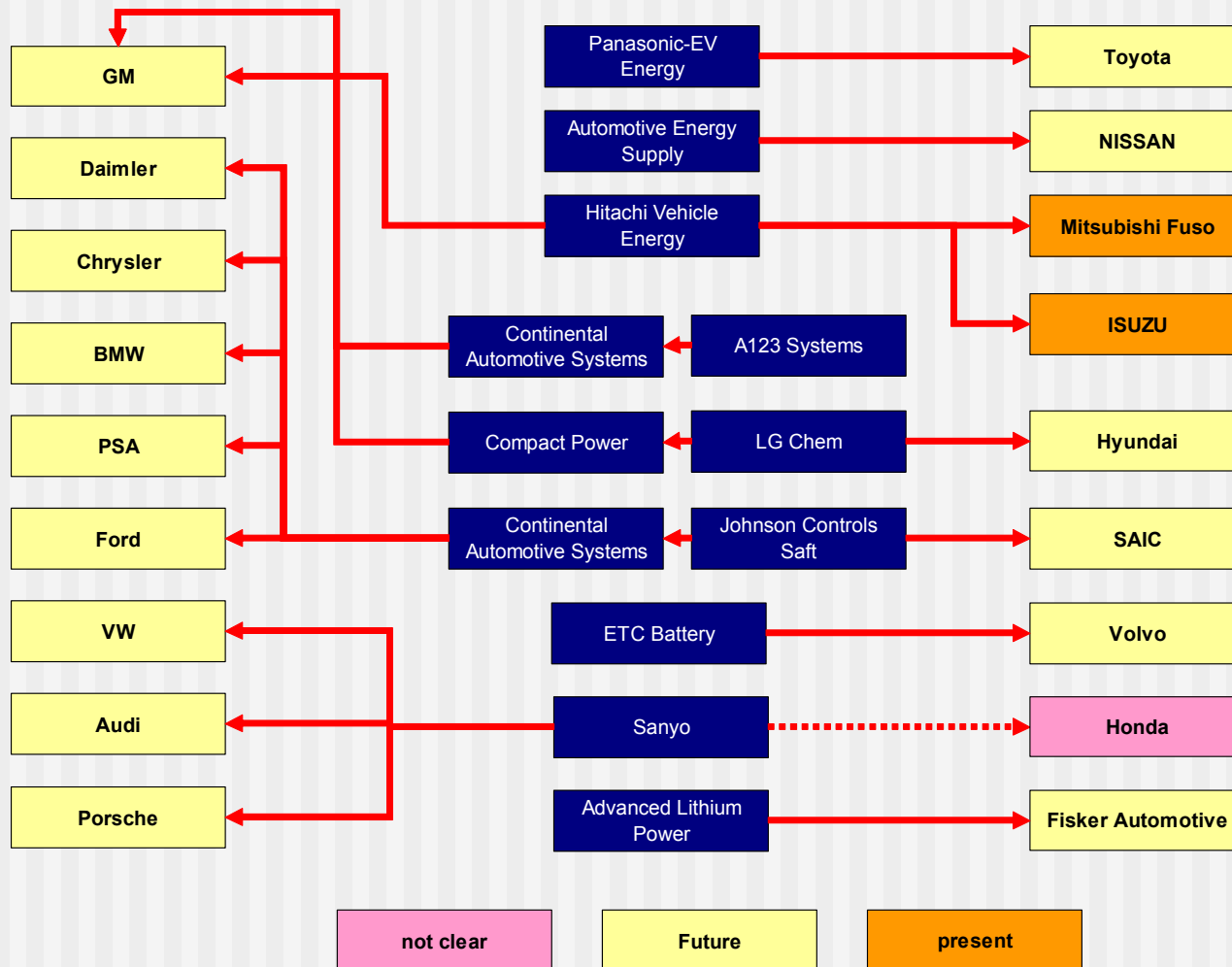

FULL-Hybrid / Ni-MH

THS vs Two-Mode-Hybrid
FULL-HybridはNi-MH Battery

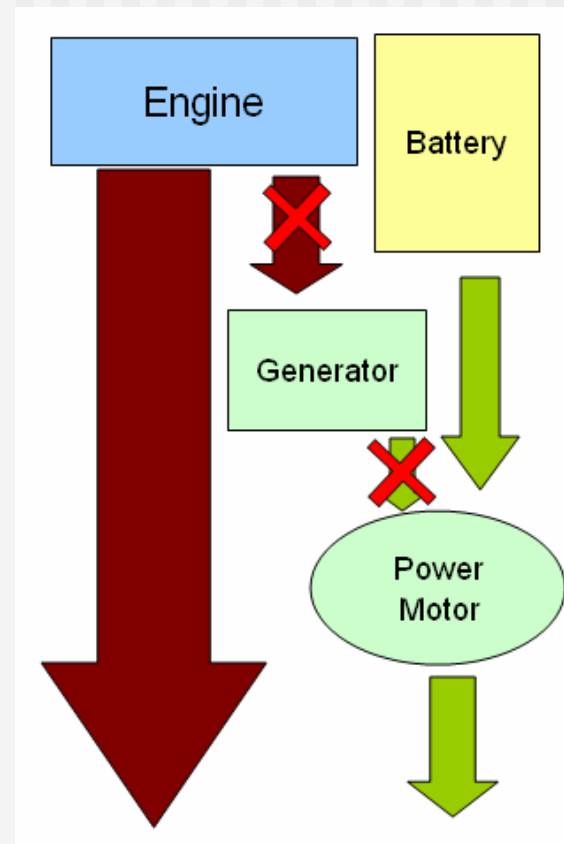
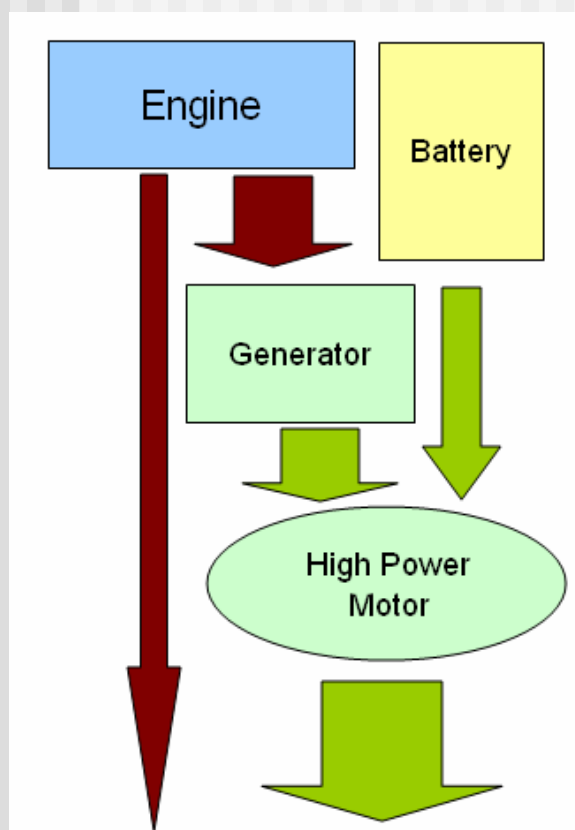
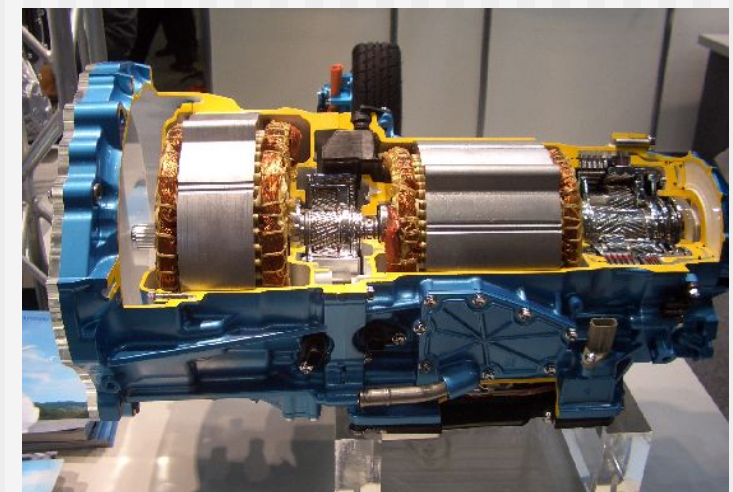
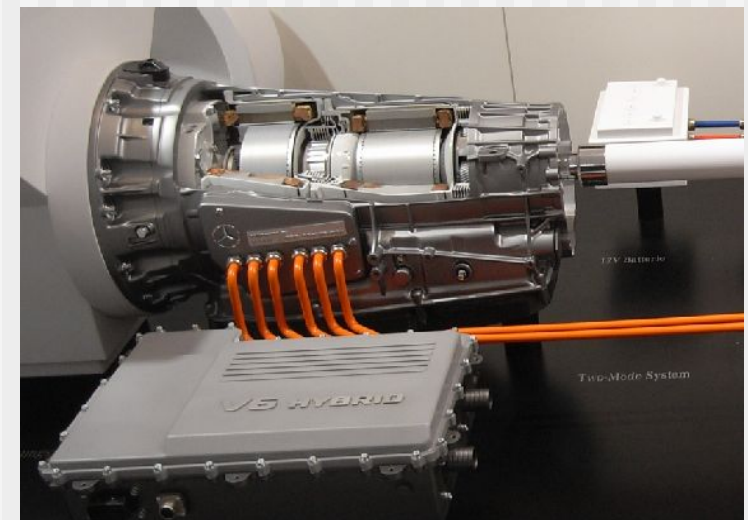

GM Chevrolet Tahoe Hybrid



初のTwo-Mode-Hybrid

2007年末から 約2万台/年

PEVEのNi-MH Battery

Daimler / Chryslerにも供給

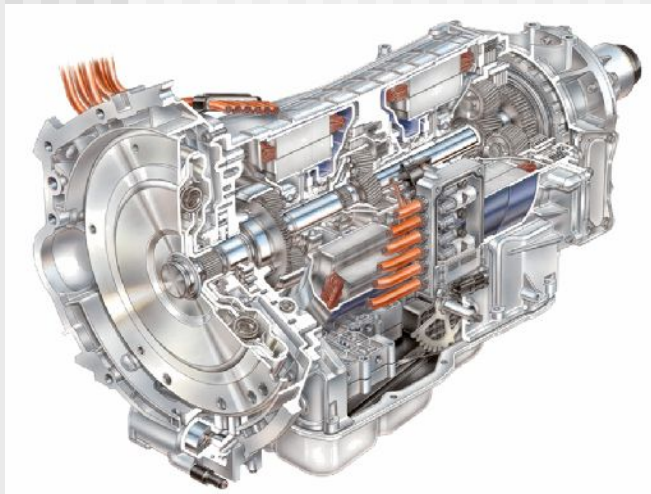

Model	Chevrolet Tahoe Hybrid GMC Yukon Hybrid
Engine	VORTEC 6.0L V-8 with cam phasing and late intake valve closing
Hybrid System	Two-Mode-Hybrid
Motor Type	AC Motor
Engine Power PS/r.p.m.	332 / 5100
Engine Torque lb-ft/r.p.m.	367 / 4100
Motor Power kW	60 × 2
Battery pack	Ni-MH 300 V
Fuel Economy	21/22 mpg (2WD)

Toyota Crown Hybrid



Lexus GS450hと共通

2008年から 約4000台/年～

PEVEのNi-MH Battery



Model	Crown Hybrid
Engine	V型6気筒DOHC
Transmission	自動無段変速機
Hybrid System	LHS
Motor Type	交流同期電動機
Engine Power kW(PS)/r.p.m.	218(296)/6400
Engine Torque N·m([kg·m])/r.p.m.	368(37.5)/4800
Motor Power kW(PS)	147(200)
Motor Torque N·m(kg·m)	275(28.0)
Battery pack	Ni-MH 288V
Fuel economy	15.8km/L

Honda Fit Hybrid



IMA Typeの Hybrid System

2015年から 25万台/年～

Small Hybrid → Idling Stop?

Sanyo/PanasonicのNi-MH Battery

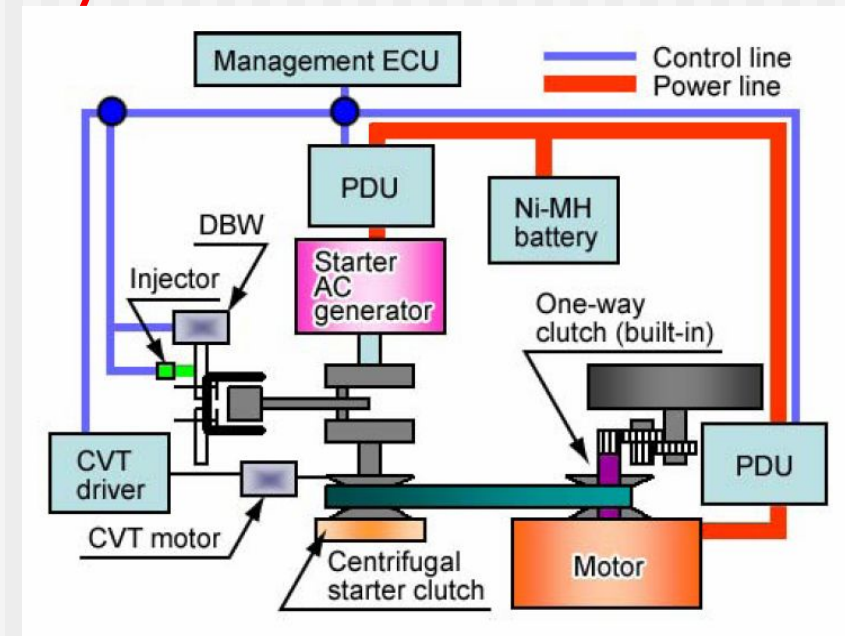

Ni-MH Battery Supplier

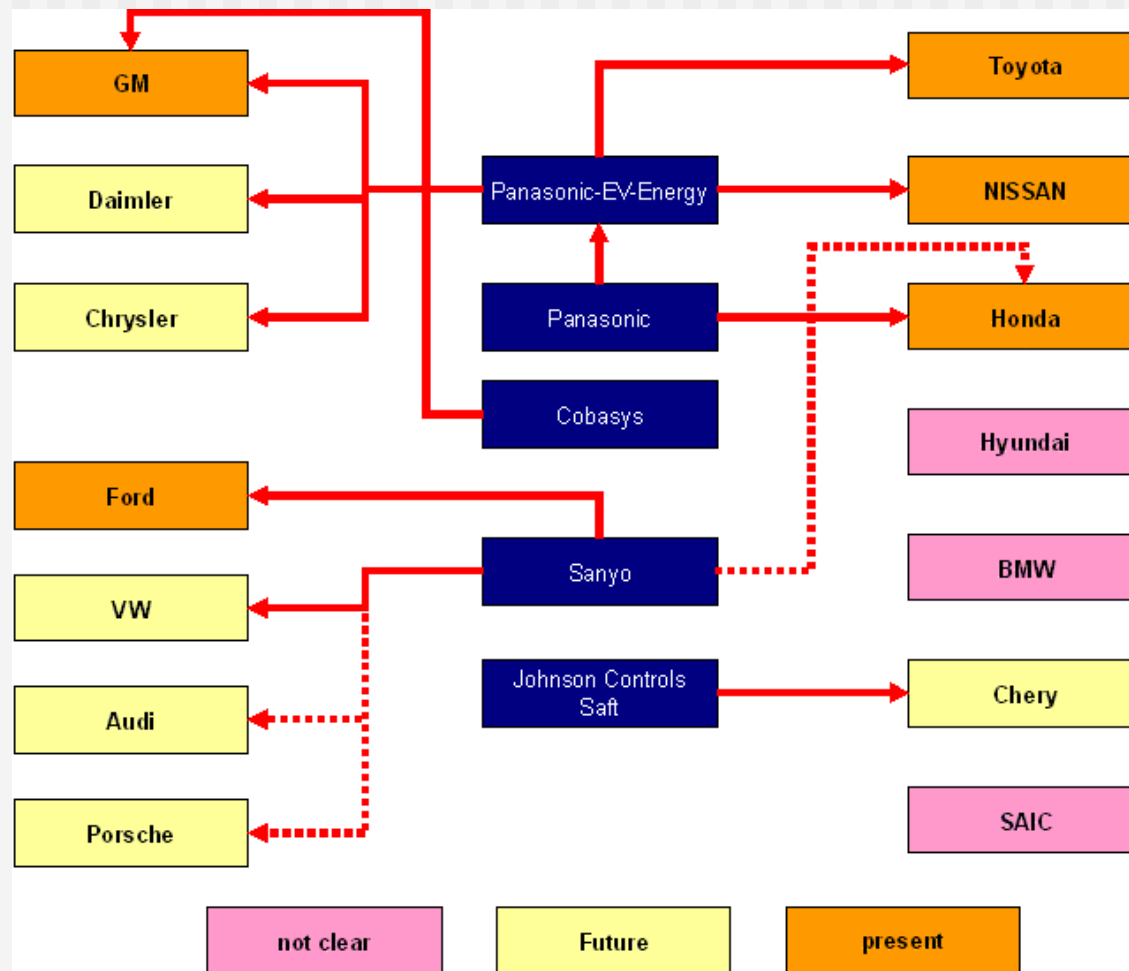

Plug-in Hybrid

- 2010年 Toyota / GM 発売
- FULL-Hybrid Type Plug-in Hybrid
- 高容量LIBの試験的採用



Model	Prius Plug-in Hybrid
Engine	1496CC
Hybrid System	THS II
Motor Type	交流同期電動機
Engine Power kW(PS)/r.p.m.	56(76)/5000
Engine Torque N·m([kg·m])/r.p.m.	110 (11.2)/4000
Motor Power kW(PS)	50 (68) / 1200~1540
Motor Torque N·m(kg·m)	400 (40.8) / 0~1200
Battery pack	Ni-MH 202V
Battery Capacity	6.5 Ah × 2 (13Ah)
System Max Power kw(PS)	100 (136)
EV Drive Range	13 km (10・15 Mode)
EV Drive Max speed	100 km/h
Battery Charge	1~1.5h (200V) 3~4h (100V)

Range Extender Plug-in Hybrid

- 2012年以降に本格化
- Series Hybrid Type
- 大容量LIB → LiMn₂O₄系/LiFePO₄系



Hybridの方向性

- FULL-Hybridは高出力化
- Plug-in Hybridは高容量化
- MILD-Hybridは中出力、汎用化
- MICRO-Hybridは標準搭載へ

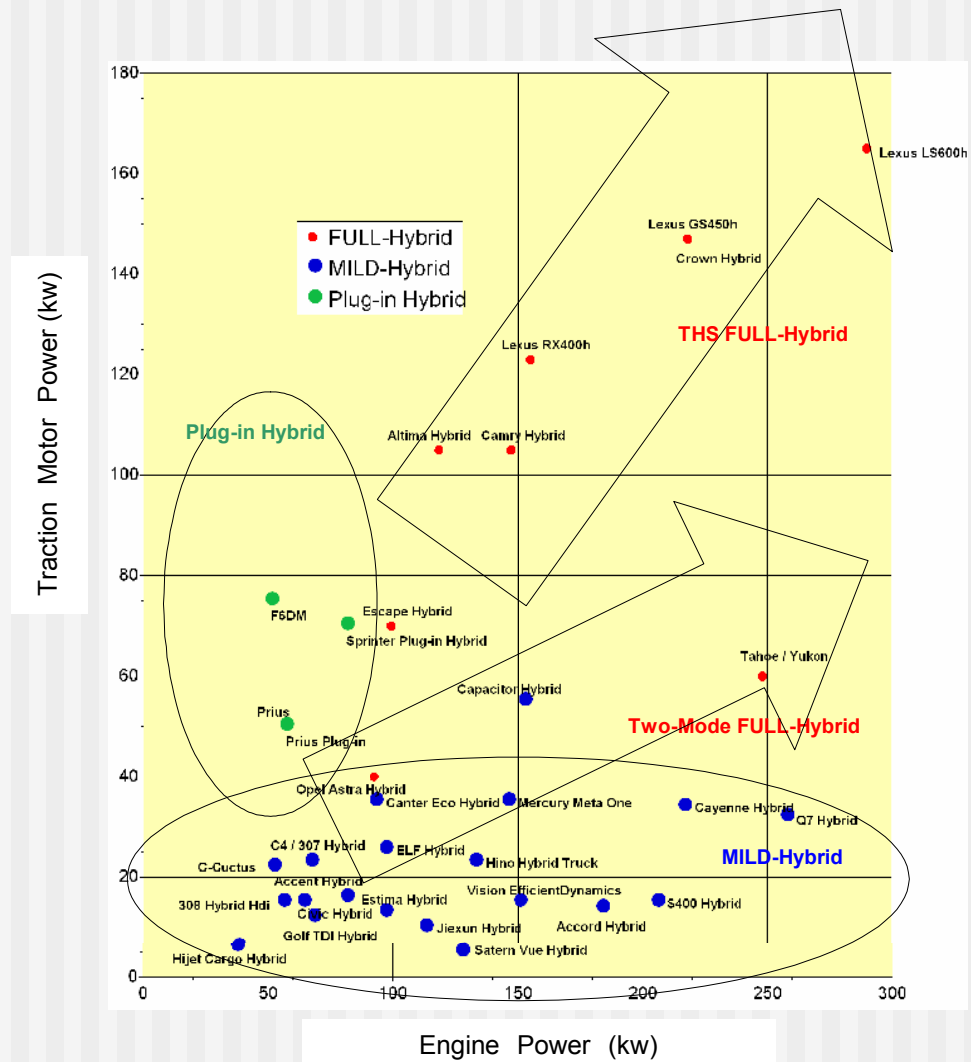

LIBは二極化

- 120V LIBによるMILD-Hybrid
- 高容量LIBでPlug-in Hybrid
- FULL-HybridはNi-MH
- FULL-HybridはRange Extender Plug-in に移行

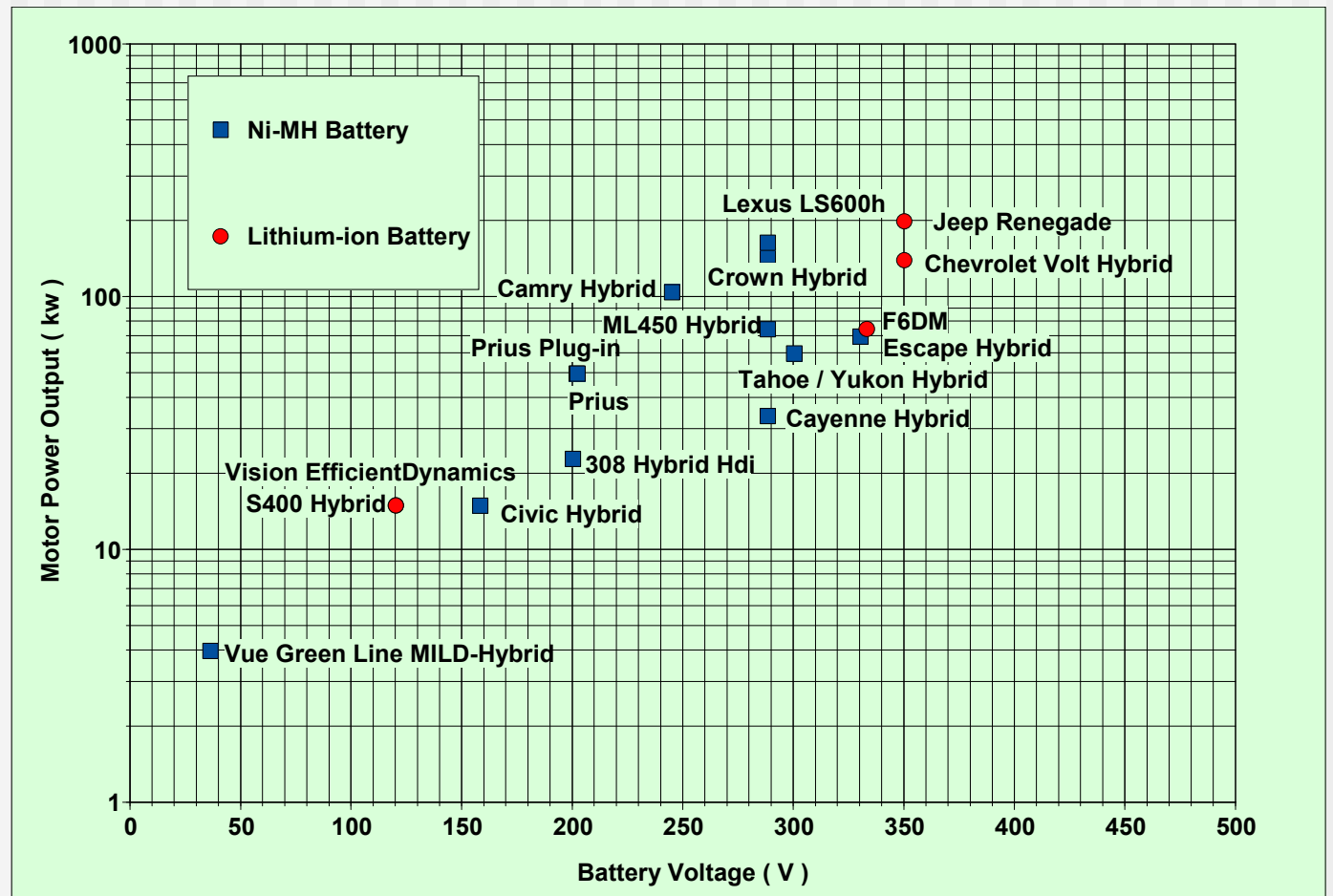

LIB Cost Reduction

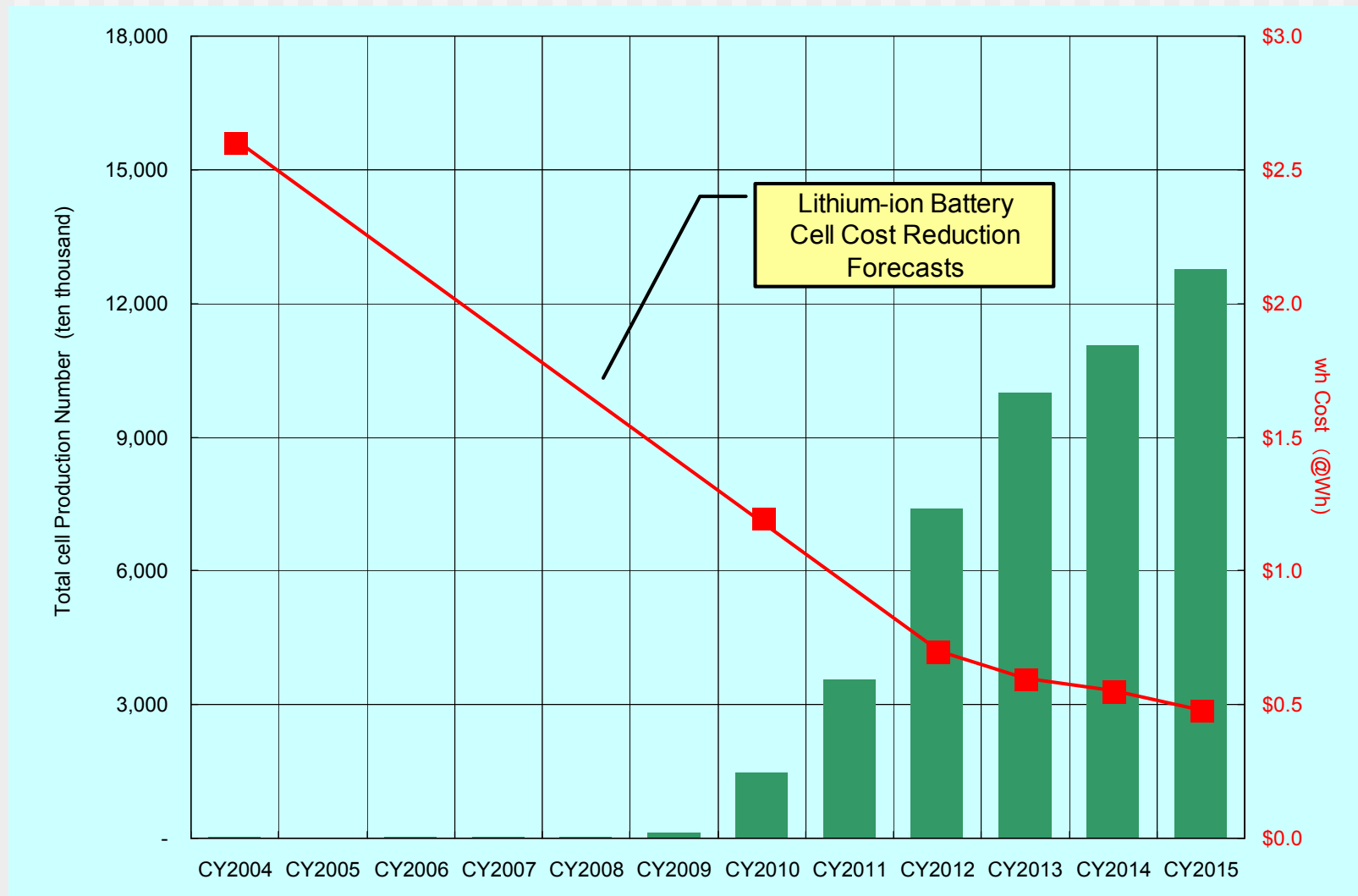

Capacitorの可能性

- Maxwell / Valeo
- Maxwell / Saft
- Furukawa
UltraBattery のConcept
- Panasonic Electronic
Devicesの展開

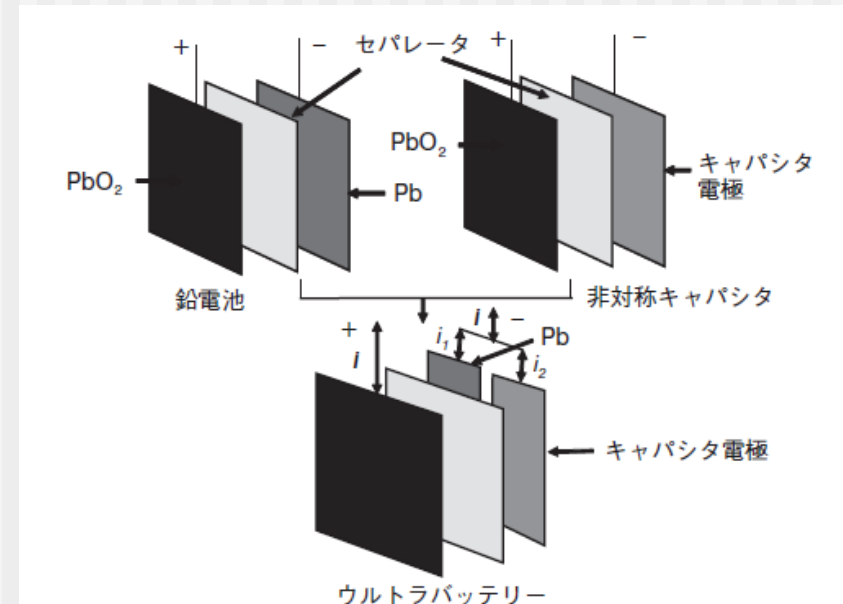
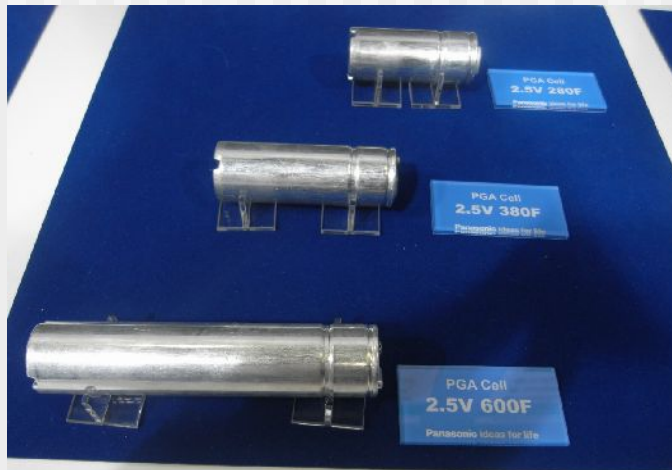

Application	Power Density (kW/L)	Energy Density (Wh/L)
Starter Generator	5	4-10
Regenerative braking	10-20	7
Boosting	20-50	10-20
X by wire	0.1	0.5

Energy Storageの棲み分け

Type	Status	Future	Energy Storage
MICRO-Hybrid	Pb-Acid とCapacitor併用、Pb-Acid のみ	今後はPb-Acid とCapacitor併用での大幅な普及が予測される。	Pb-Acid + Capacitor
NIB MILD-Hybrid	Ni-MH による市場形成がなされたが今後は成長性低い。	MILD-Hybridでは新規参入MakerがLIBに移行していく。	×
LIB MILD-Hybrid	LIBでのMILD-Hybrid新規参入増加。LiNiO ₂ 系もしくはComposite系などでCylindrical Type 中心。		LiNiO ₂ / Composite/Cylindrical Lithium-ion Battery
NIB FULL-Hybrid	Ni-MH Batteryによる市場拡大。今後の新規参入もNi-MH Batteryを採用。FULL-Hybridは長期的にはPlug-in Hybridに移行してLIB搭載へ。		Ni-MH Battery
LIB FULL-Hybrid	LIB 搭載 FULL-Hybridは、Plug-in Hybridに移行。		×
MILD-Hybrid Plug-in	MILD-Hybrid TypeのPlug-in Hybridは、Fleet 用途に限定され市場成長性は低い。LIB採用が中心とみられるが、Capacitorの採用もある。		(LIB, Capacitor)
FULL-Hybrid Plug-in	FULL-Hybrid TypeのPlug-in Hybridは初期の実用化に限られる。LIBの採用が中心だが、試験的にNi-MH Batteryの採用もある。		(LIB, Ni-MH)
Range Extender Plug-in	高電圧 / 高容量 / 低CostのBatteryが必要となるため、Laminated TypeのLiMn ₂ O ₄ 系もしくはLiFePO ₄ 系によるLithium-ion Batteryが使用される見込み。		LiMn ₂ O ₄ / LiFePO ₄ / Laminated Lithium-ion Battery

Hybrid Market Forecasts

**CY2015 Hybrid Market 4,360,000 units
(Estimated by HIEDGE)**

